

EP series



Combined gear reducers

Edition April 2018

Contents

1 - Product range	4
2 - Design Features	5
Ordering code	5
3 - R 1EL + R CI - Selection tables	6
Summary of transmission ratios i_{eff} , nominal M_{N2} and peak M_{2max} torques $L_n = 10\ 000$ h	6-7
Summary of transmission ratios i_{eff} , nominal M_{N2} and peak M_{2max} torques $L_n = 25\ 000$ h	8-9
Summary of transmission ratios i_{eff} , nominal M_{N2} and peak M_{2max} torques $L_n = 50\ 000$ h	10-11
4 - R 2EL + R CI - Selection tables	12
Summary of transmission ratios i_{eff} , nominal M_{N2} and peak M_{2max} torques $L_n = 10\ 000$ h	12-13
Summary of transmission ratios i_{eff} , nominal M_{N2} and peak M_{2max} torques $L_n = 25\ 000$ h	14-15
Summary of transmission ratios i_{eff} , nominal M_{N2} and peak M_{2max} torques $L_n = 50\ 000$ h	16-17
5 - Main Dimensions	18
Cylindrical Shaft	18
Splined Shaft	19
Hollow Shaft	20
Splined Hollow Shaft	21
R 1EL .. + R CI .. Overall dimensions	22
R 2EL .. + R CI .. Overall dimensions	23
6 - Mounting positions	25
Oil quantity and mass, Thermal Power (P_t) effects, radial (F_r) and axial (F_a) loads	25
7 - Accessories	26

1 - Product range

Size

M_{N2max} [kN m]

F_{r2} [kN] - cylindrical shaft

F_{r2} [kN] - splined shaft

Train of gears

i_N

R 1EL + R CI

16 ... 160

R 1EL 042A + R CI 180

67
132
140



R 1EL 060A + R CI 200

90
140
160

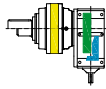

R 1EL 085A + R CI 225

140
200
224

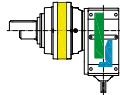

R 1EL 125A + R CI 250

200
250
280

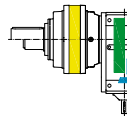

R 1EL 180A + R CI 280

280
355
375

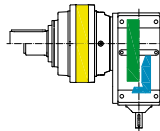

R 1EL 250A + R CI 320

400
375
425

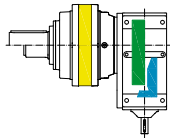

R 2EL + R CI

112 ... 500

R 2EL 125A + R CI 180

125
250
280

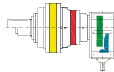

R 2EL 180A + R CI 200

180
355
375

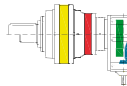

R 2EL 250A + R CI 225

265
375
425

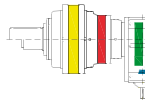

R 2EL 355A + R CI 250

375
530
560

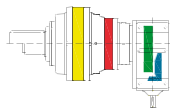

R 2EL 500A + R CI 280

530
670
710

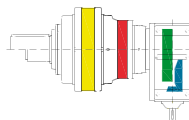

R 2EL 710A + R CI 320

710
800
850

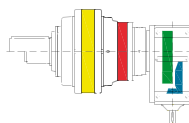

2 - Design features

Ordering code

Gearbox size and ratio				Output		Input						
R	2EL	250A	+	R	CI	225	290Y	C220M1	F10k	C48x110	B53	,...
												ACCESSORIES
												,SW Stop washer
												,SB Splined bush
												,WF Wheel flange
												,SC Splined bar
												,FB Foot bracket
												,SD Shrink disc
												MOUNTING POSITION
												B5, V1, V3 ...
												SHAFT DIMENSIONS
												INPUT
												C... cylindrical shaft end
												I IEC electric motor adapter
												OUTPUT MODEL
												10, 20, 30 ... model
												a ... z coupling dimensions
												MOUNTING
												F with flange
												A shaft mounting
												OUTPUT SHAFT DIMENSIONS
												120 ... 340 shaft diameter
												M metric
												1 ... 9 model
												SHAFT END
												C cylindrical S splined
												H hollow Z splined hollow
												TYPE OF RATIO
												Y standard ratio
												Z non-standard ratio
												TRANSMISSION RATIO
												BEVEL-HELICAL UNIT
												STAGE COMPOSITION
												A standard stage composition
												Z special stage composition
												SIZE
												125 ... 710
												TRAIN OF GEARS PLANETARY
												1EL 1 stage in line
												2EL 2 stages in line
												MACHINE

Options available on request

3 - Selection tables

R 1EL .. + R CI ..

$L_h = 10\ 000\ h$

Summary of transmission ratios i_{eff} nominal M_{N2} and peak M_{2max} torques

		Gear reducer size																	
		R 1EL 042A + R CI 180					R 1EL 060A + R CI 200					R 1EL 085A + R CI 225							
		n_1 min ⁻¹					n_1 min ⁻¹					n_1 min ⁻¹							
		n_2 min ⁻¹	M_{N2max}	M_{2max}			n_2 min ⁻¹	M_{N2max}	M_{2max}			n_2 min ⁻¹	M_{N2max}	M_{2max}					
		M_{N2} kN m	kN m	kN m			M_{N2} kN m	kN m	kN m			M_{N2} kN m	kN m	kN m					
i_N	i_{eff}	1400	900	500			i_{eff}	1400	900	500			i_{eff}	1400	900	500			
16							17,0	83,5	53,7	29,8									
								17,6	18,3	19,3	25,1	50,3							
22							21,0	67	43,1	23,9									
								21,9	23,3	27,6	35,9	71,8							
28							27,0	52,2	33,5	18,6									
								28,2	29,8	35,4	46,1	90,0							
36	35,0	40,3	25,9	14,4			34,0	40,8	26,3	14,6			34,0	41,2	26,5	14,7			
		21,0	21,9	25,9	33,6	67,0		36,0	37,2	38,5	56,0	90,0		40,6	43,5	50,1	65,1	130	
40	41,0	34,5	22,2	12,3			43,0	32,2	20,7	11,5			43,0	32,5	20,9	11,6			
		24,6	25,6	30,2	39,3	67,0		36,7	37,7	39,0	56,0	90,0		51,5	55,2	62,1	80,0	140	
45	46,0	30,7	19,7	11			47,0	29,9	19,2	10,7			49,0	28,3	18,2	10,1			
		27,4	28,5	31,3	40,0	67,0		37,0	38,0	39,4	56,0	90,0		58,4	60,5	62,7	80,0	140	
50	51,0	27,5	17,7	9,83			54,0	25,9	16,6	9,25			54,0	25,9	16,7	9,26			
		25,8	26,8	28,4	36,9	67,0		37,2	38,3	39,7	56,0	90,0		54,8	56,7	59,6	77,4	140	
63	57,0	24,5	15,7	8,74			59,0	23,6	15,2	8,43			62,0	22,6	14,5	8,07			
		28,7	29,5	30,2	39,3	67,0		37,5	38,5	39,9	56,0	90,0		59,6	61,3	63,5	80,0	140	
71	64,0	21,9	14,1	7,81			68,0	20,5	13,2	7,33			68,0	20,7	13,3	7,38			
		24,4	25,4	31,2	40,0	67,0		37,7	38,9	40,2	56,0	90,0		54,4	55,2	59,6	77,4	140	
75	72,0	19,5	12,5	6,96			75,0	18,8	12,1	6,71			78,0	18	11,6	6,42			
		27,4	28,5	32,1	40,0	67,0		38,0	39,0	40,5	56,0	90,0		60,5	62,1	64,5	80,0	140	
80	78,0	17,9	11,5	6,39			81,0	17,2	11,1	6,14			85,0	16,5	10,6	5,9			
		26,5	28,8	32,1	40,0	67,0		38,3	39,0	40,5	56,0	90,0		60,8	62,7	65,1	80,0	140	
90	91,0	15,3	9,84	5,47			95,0	14,8	9,52	5,29			99,0	14,1	9,09	5,05			
		26,0	26,0	26,0	33,8	67,0		38,5	39,7	40,9	56,0	90,0		55,6	55,6	55,6	72,3	140	
100	99,0	14,1	9,07	5,04			103	13,5	8,7	4,83			107	13	8,37	4,65			
		25,3	26,5	27,5	35,7	67,0		38,9	39,9	41,5	56,0	90,0		54,8	57,1	59,6	77,4	140	
125							129	10,8	6,97	3,87									
								37,8	39,2	41,7	54,3	90,0							
160							162	8,66	5,57	3,09									
								34,5	32,1	34,5	44,8	89,6							

3 - Selection tables

R 1EL .. + R CI ..

$L_h = 10\ 000\ h$

Summary of transmission ratios i_{eff} , nominal M_{N2} and peak M_{2max} torques

		Gear reducer size																									
		R 1EL 125A + R CI 250					R 1EL 180A + R CI 280					R 1EL 250A + R CI 320															
		n_1		n_2		M_{N2max}		M_{2max}		n_1		n_2		M_{N2max}		M_{2max}		n_1		n_2		M_{N2max}		M_{2max}			
		min ⁻¹		min ⁻¹		kN m		kN m		min ⁻¹		min ⁻¹		kN m		kN m		min ⁻¹		min ⁻¹		kN m		kN m			
i_N	i_{eff}	1400	900	500						i_{eff}	1400	900	500						i_{eff}	1400	900	500					
16	17,0	83,9	53,9	29,9															16,0	85,8	55,2	30,7					
		35,1	36,5	38,2	49,6	99,3														61,2	63,6	66,5	86,4	173			
22	21,0	66,3	42,6	23,7																20,0	68,5	44	24,4				
		44,3	46,1	57,9	75,3	151														76,6	79,6	98,8	128	257			
28	27,0	52,3	33,6	18,7																26,0	53,4	34,3	19,1				
		56,2	58,5	73,5	95,5	191														98,2	102	125	163	326			
36	35,0	40,3	25,9	14,4					34,0	41,1	26,4	14,7								31,0	45,7	29,4	16,3				
		73,1	76,0	81,8	112	200				81,4	84,8	105,1	137	273						115	119	147	191	381			
40	43,0	32,2	20,7	11,5					40,0	35,1	22,6	12,5								38,0	36,6	23,5	13,1				
		78,0	80,1	82,8	112	200				95,2	99,1	122,8	160	280						123	127	147	191	381			
45	48,0	29,3	18,8	10,4					44,0	31,8	20,5	11,4								43,0	32,7	21	11,7				
		78,5	80,7	83,7	112	200				104	108	124	160	280						136	141	165	215	400			
50	53,0	26,4	17	9,44					50,0	28,1	18	10								50,0	28,1	18	10				
		79,0	81,2	84,2	112	200				100	104	125	160	280						141	146	174	226	400			
63	60,0	23,2	14,9	8,28					55,0	25,3	16,3	9,05								54,0	26	16,7	9,3				
		79,6	81,8	84,7	112	200				110	115	126	160	280						128	133	151	196	393			
71	67,0	21	13,5	7,5					63,0	22,2	14,3	7,93								63,0	22,4	14,4	7,99				
		80,1	82,5	85,4	112	200				94,2	98,1	103	133	267						127	132	142	184	369			
75	75,0	18,8	12,1	6,7					69,0	20,2	13	7,2								69,0	20,2	13	7,2				
		80,7	82,8	86,1	112	200				104	108	116	150	280						135	140	165	215	400			
80	85,0	16,5	10,6	5,9					77,0	18,1	11,7	6,47								80,0	17,6	11,3	6,27				
		81,2	83,7	86,9	112	200				106	109	123	160	280						127	131	142	184	369			
90	95,0	14,8	9,5	5,28					88,0	15,9	10,2	5,68								88,0	15,9	10,2	5,68				
		81,8	84,2	87,3	112	200				99,4	99,4	99,7	130	259						124	127	100	191	381			
100	107	13	8,37	4,65					98,0	14,3	9,2	5,11								96,0	14,5	9,34	5,19				
		82,5	84,7	88,1	112	200				100	104	110	143	280						128	130	147	215	400			
125	134	10,4	6,69	3,72																							
		78,1	81,4	86,6	112	200																					
160	168	8,34	5,36	2,98																							
		71,5	67,0	71,5	92,9	186																					

3 - Selection tables

R 1EL .. + R CI ..

$L_h = 25\ 000\ h$

Summary of transmission ratios i_{eff} , nominal M_{N2} and peak M_{2max} torques

		Gear reducer size														
		R 1EL 042A + R CI 180					R 1EL 060A + R CI 200					R 1EL 085A + R CI 225				
		n_1 min ⁻¹		M_{N2max} M_{2max}		n_1 min ⁻¹		M_{N2max} M_{2max}		n_1 min ⁻¹		M_{N2max} M_{2max}				
		n_2 min ⁻¹	M_{N2} kN m	M_{2max} kN m	M_{2max} kN m	n_2 min ⁻¹	M_{N2} kN m	M_{2max} kN m	M_{2max} kN m	n_2 min ⁻¹	M_{N2} kN m	M_{2max} kN m	M_{2max} kN m	M_{2max} kN m	M_{2max} kN m	
i_N	i_{eff}	1400	900	500		i_{eff}	1400	900	500		i_{eff}	1400	900	500		
16						17,0	83,5	53,7	29,8							
							15,7	16,4	17,3	25,1	50,3					
22						21,0	67	43,1	23,9							
							19,6	20,8	24,7	35,9	71,8					
28						27,0	52,2	33,5	18,6							
							25,1	26,6	31,6	46,1	90,0					
36	35,0	40,3	25,9	14,4		34,0	40,8	26,3	14,6		34,0	41,2	26,5	14,7		
		18,8	19,6	23,1	33,6	67,0	32,2	34,0	36,4	56,0	90,0	36,2	38,9	44,7	65,1	130
40	41,0	34,5	22,2	12,3		43,0	32,2	20,7	11,5		43,0	32,5	20,9	11,6		
		22,0	22,9	27,0	39,3	67,0	34,7	35,7	37,0	56,0	90,0	45,9	49,3	56,7	80,0	140
45	46,0	30,7	19,7	11		47,0	29,9	19,2	10,7		49,0	28,3	18,2	10,1		
		24,5	25,4	29,5	40,0	67,0	35,0	35,9	37,2	56,0	90,0	52,1	54,5	59,2	80,0	140
50	51,0	27,5	17,7	9,83		54,0	25,9	16,6	9,25		54,0	25,9	16,7	9,26		
		23,1	24,0	25,4	36,9	67,0	35,2	36,2	37,5	56,0	90,0	48,9	50,6	53,2	77,4	140
63	57,0	24,5	15,7	8,74		59,0	23,6	15,2	8,43		62,0	22,6	14,5	8,07		
		25,6	26,3	27,0	39,3	67,0	35,2	36,4	37,7	56,0	90,0	55,3	57,9	58,5	80,0	140
71	64,0	21,9	14,1	7,81		68,0	20,5	13,2	7,33		68,0	20,7	13,3	7,38		
		21,8	22,7	27,8	40,0	67,0	35,7	36,7	38,3	56,0	90,0	48,6	49,3	53,2	77,4	140
75	72,0	19,5	12,5	6,96		75,0	18,8	12,1	6,71		78,0	18,0	11,6	6,42		
		24,5	25,4	30,3	40,0	67,0	35,9	36,9	38,3	56,0	90,0	54,1	56,5	60,3	80,0	140
80	78,0	17,9	11,5	6,39		81,0	17,2	11,1	6,14		85,0	16,5	10,6	5,9		
		23,7	25,7	30,3	40,0	67,0	36,2	37,0	38,5	56,0	90,0	55,8	58,4	61,3	80,0	140
90	91,0	15,3	9,84	5,47		95,0	14,8	9,52	5,29		99,0	14,1	9,09	5,05		
		23,2	23,2	23,2	33,8	67,0	36,4	37,5	38,5	56,0	90,0	49,6	49,6	49,6	72,3	140
100	99,0	14,1	9,07	5,04		103	13,5	8,7	4,83		107	13,0	8,37	4,65		
		22,6	23,7	24,6	35,7	67,0	36,7	37,7	39,0	56,0	90,0	48,9	51,0	53,2	77,4	140
125						129	10,8	6,97	3,87							
							33,7	35,0	37,3	54,3	90,0					
160						162	8,66	5,57	3,09							
							30,8	28,7	30,8	44,8	89,6					

3 - Selection tables

R 1EL .. + R CI ..

$L_h = 25\ 000\ h$

Summary of transmission ratios i_{eff} , nominal M_{N2} and peak M_{2max} torques

		Gear reducer size																	
		R 1EL 125A + R CI 250					R 1EL 180A + R CI 280					R 1EL 250A + R CI 320							
		n_1 min ⁻¹		M_{N2max} kN m		M_{2max} kN m		n_1 min ⁻¹		M_{N2max} kN m		M_{2max} kN m		n_1 min ⁻¹		M_{N2max} kN m		M_{2max} kN m	
i_N	i_{eff}	1400	900	500															
16	17,0	83,9	53,9	29,9										16,0	85,8	55,2	30,7		
		31,3	32,6	34,1	49,6	99,3									54,6	56,8	59,4	86,4	173
22	21,0	66,3	42,6	23,7										20,0	68,5	44	24,4		
		39,6	41,2	51,7	75,3	151									68,4	71,1	88,2	128	257
28	27,0	52,3	33,6	18,7										26,0	53,4	34,3	19,1		
		50,2	52,3	65,6	95,5	191									87,7	91,1	112	163	326
36	35,0	40,3	25,9	14,4			34,0	41,1	26,4	14,7				31,0	45,7	29,4	16,3		
		62,9	67,9	77,3	112	200		72,7	75,7	93,8	137	273			101	106	131	191	381
40	43,0	32,2	20,7	11,5			40,0	35,1	22,6	12,5				38,0	36,6	23,5	13,1		
		67,1	73,1	78,4	112	200		77,8	88,5	107	160	280			107	114	131	191	381
45	48,0	29,3	18,8	10,4			44,0	31,8	20,5	11,4				43,0	32,7	21	11,7		
		70,1	76,3	79,0	112	200		81,2	92,8	110	160	280			111	124	147	215	400
50	53,0	26,4	17	9,44			50,0	28,1	18	10				50,0	28,1	18	10		
		72,1	76,8	79,6	112	200		83,5	92,8	114	160	280			115	130	156	226	400
63	60,0	23,2	14,9	8,28			55,0	25,3	16,3	9,05				54,0	26	16,7	9,3		
		71,8	74,7	80,1	112	200		86,6	99,2	113	160	280			114	119	132	196	393
71	67,0	21	13,5	7,5			63,0	22,2	14,3	7,93				63,0	22,4	14,4	7,99		
		75,7	77,8	80,7	112	200		84,1	87,6	91,7	133	267			114	118	127	184	369
75	75,0	18,8	12,1	6,7			69,0	20,2	13	7,2				69,0	20,2	13	7,2		
		76,3	78,4	81,2	112	200		92,8	96,7	103	150	280			121	125	147	215	400
80	85,0	16,5	10,6	5,9			77,0	18,1	11,7	6,47				80,0	17,6	11,3	6,27		
		76,8	79,0	81,8	112	200		94,4	97,0	110	160	280			113	117	127	184	369
90	95,0	14,8	9,5	5,28			88,0	15,9	10,2	5,68				88,0	15,9	10,2	5,68		
		77,3	79,6	82,5	112	200		88,8	88,8	89,0	130	259			110	113	89	191	381
100	107	13	8,37	4,65			98,0	14,3	9,2	5,11				96	14,5	9,34	5,19		
		75,5	77,9	82,8	112	200		89,2	93,0	98,2	143	280			114	116	131	215	400
125	134	10,4	6,69	3,72															
		69,7	72,6	77,3	112	200													
160	168	8,34	5,36	2,98															
		63,8	59,8	63,8	92,9	186													

3 - Selection tables

R 1EL .. + R CI ..

$L_h = 50\ 000\ h$

Summary of transmission ratios i_{eff} , nominal M_{N2} and peak M_{2max} torques

		Gear reducer size																		
		R 1EL 042A + R CI 180					R 1EL 060A + R CI 200					R 1EL 085A + R CI 225								
		n_1 min ⁻¹		M_{N2max} kN m		M_{2max} kN m		n_1 min ⁻¹		M_{N2max} kN m		M_{2max} kN m		n_1 min ⁻¹		M_{N2max} kN m		M_{2max} kN m		
		n_2 min ⁻¹	M_{N2} kN m	M_{N2max} kN m	M_{2max} kN m	M_{2max} kN m	n_2 min ⁻¹	M_{N2} kN m	M_{N2max} kN m	M_{2max} kN m	M_{2max} kN m	n_2 min ⁻¹	M_{N2} kN m	M_{N2max} kN m	M_{2max} kN m	M_{2max} kN m	n_2 min ⁻¹	M_{N2} kN m	M_{N2max} kN m	M_{2max} kN m
i_N	i_{eff}	1400	900	500			i_{eff}	1400	900	500			i_{eff}	1400	900	500				
16							17,0	83,5	53,7	29,8										
								13,3	13,9	14,6	25,1	50,3								
22							21,0	67	43,1	23,9										
								16,6	17,6	20,9	35,9	71,8								
28							27,0	52,2	33,5	18,6										
								21,3	22,6	26,8	46,1	90,0								
36	35,0	40,3	25,9	14,4			34,0	40,8	26,3	14,6			34,0	41,2	26,5	14,7				
		15,9	16,6	19,6	33,6	67,0		27,3	28,9	34,3	56,0	90,0		30,7	33,0	37,9	65,1	130		
40	41,0	34,5	22,2	12,3			43,0	32,2	20,7	11,5			43,0	32,5	20,9	11,6				
		18,6	19,4	22,9	39,3	67,0		30,9	34,2	35,4	56,0	90,0		39,0	41,8	48,1	80,0	140		
45	46,0	30,7	19,7	11			47,0	29,9	19,2	10,7			49,0	28,3	18,2	10,1				
		20,7	21,6	25,7	40,0	67,0		31,9	34,4	35,7	56,0	90,0		42,8	46,2	54,1	80,0	140		
50	51,0	27,5	17,7	9,83			54,0	25,9	16,6	9,25			54,0	25,9	16,7	9,26				
		19,6	20,3	21,5	36,9	67,0		32,9	34,7	35,9	56,0	90,0		41,5	42,9	45,1	77,4	140		
63	57,0	24,5	15,7	8,74			59,0	23,6	15,2	8,43			62,0	22,6	14,5	8,07				
		21,7	22,3	22,9	39,3	67,0		29,8	31,1	34,3	56,0	90,0		45,6	49,2	49,6	80,0	140		
71	64,0	21,9	14,1	7,81			68,0	20,5	13,2	7,33			68,0	20,7	13,3	7,38				
		18,5	19,2	23,6	40,0	67,0		34,2	35,2	36,4	56,0	90,0		41,2	41,8	45,1	77,4	140		
75	72,0	19,5	12,5	6,96			75,0	18,8	12,1	6,71			78,0	18,0	11,6	6,42				
		20,7	21,6	26,4	40,0	67,0		34,0	35,4	36,7	56,0	90,0		45,9	47,9	51,1	80,0	140		
80	78,0	17,9	11,5	6,39			81,0	17,2	11,1	6,14			85,0	16,5	10,6	5,9				
		20,1	21,8	25,7	40,0	67,0		33,6	34,1	36,9	56,0	90,0		47,3	49,5	55,6	80,0	140		
90	91,0	15,3	9,84	5,47			95,0	14,8	9,52	5,29			99,0	14,1	9,09	5,05				
		19,7	19,7	19,7	33,8	67,0		32,9	33,9	35,2	56,0	90,0		42,1	42,1	42,1	72,3	140		
100	99,0	14,1	9,07	5,04			103	13,5	8,7	4,83			107	13,0	8,37	4,65				
		19,2	20,1	20,8	35,7	67,0		31,8	33,0	37,5	56,0	90,0		41,5	43,3	45,1	77,4	140		
125							129	10,8	6,97	3,87										
								28,6	29,7	31,6	54,3	90,0								
160							162	8,66	5,57	3,09										
								26,1	24,3	26,1	44,8	89,6								

3 - Selection tables

R 1EL .. + R CI ..

$L_h = 50\ 000\ h$

Summary of transmission ratios i_{eff} , nominal M_{N2} and peak M_{2max} torques

		Gear reducer size																	
		R 1EL 125A + R CI 250					R 1EL 180A + R CI 280					R 1EL 250A + R CI 320							
		n_1 min ⁻¹			M_{N2max} M_{2max}		n_1 min ⁻¹			M_{N2max} M_{2max}		n_1 min ⁻¹			M_{N2max} M_{2max}				
		n_2 min ⁻¹	M_{N2} kN m	M_{2max} kN m	M_{N2max} kN m	M_{2max} kN m	n_2 min ⁻¹	M_{N2} kN m	M_{2max} kN m	M_{N2max} kN m	M_{2max} kN m	n_2 min ⁻¹	M_{N2} kN m	M_{2max} kN m	M_{N2max} kN m	M_{2max} kN m			
i_N	i_{eff}	1400	900	500			i_{eff}	1400	900	500			i_{eff}	1400	900	500			
16	17,0	83,9	53,9	29,9										16,0	85,8	55,2	30,7		
		26,6	27,6	28,9	49,6	99,3									46,4	48,2	50,4	86,4	173
22	21,0	66,3	42,6	23,7										20,0	68,5	44	24,4		
		33,6	35,0	43,9	75,3	151									58,0	60,3	74,8	128	257
28	27,0	52,3	33,6	18,7										26,0	53,4	34,3	19,1		
		42,6	44,3	55,6	95,5	191									74,4	77,3	95	163	326
36	35,0	40,3	25,9	14,4			34,0	41,1	26,4	14,7				31,0	45,7	29,4	16,3		
		51,1	57,6	70,1	112	200		61,7	64,2	79,6	137	273			81,7	90,4	111	191	381
40	43,0	32,2	20,7	11,5			40,0	35,1	22,6	12,5				38,0	36,6	23,5	13,1		
		55,0	62,1	74,7	112	200		63,7	72,8	87	160	280			87,3	96,4	111	191	381
45	48,0	29,3	18,8	10,4			44,0	31,8	20,5	11,4				43,0	32,7	21	11,7		
		56,9	65,0	75,7	112	200		65,9	75,4	90	160	280			90,4	104	124	215	400
50	53,0	26,4	17	9,44			50,0	28,1	18	10				50,0	28,1	18	10		
		58,5	67,0	76,3	112	200		67,8	77,8	93	160	280			93,7	107	128	226	400
63	60,0	23,2	14,9	8,28			55,0	25,3	16,3	9,05				54,0	26	16,7	9,3		
		60,7	63,4	73,1	112	200		70,3	80,6	96	160	280			97,1	101	114	196	393
71	67,0	21	13,5	7,5			63,0	22,2	14,3	7,93				63,0	22,4	14,4	7,99		
		62,9	70,1	75,2	112	200		71,4	74,3	77,8	133	267			96,4	100	108	184	369
75	75,0	18,8	12,1	6,7			69,0	20,2	13	7,2				69,0	20,2	13	7,2		
		65,0	70,2	77,8	112	200		75,4	82,0	88	150	280			102	106	125	215	400
80	85,0	16,5	10,6	5,9			77,0	18,1	11,7	6,47				80,0	17,6	11,3	6,27		
		65,3	70,8	78,5	112	200		77,8	82,3	93	160	280			95,9	100	108	184	369
90	95,0	14,8	9,5	5,28			88,0	15,9	10,2	5,68				88,0	15,9	10,2	5,68		
		66,0	67,9	73,1	112	200		75,3	75,3	75,6	130	259			93,6	96,2	75,6	191	381
100	107	13	8,37	4,65			98,0	14,3	9,2	5,11				96	14,5	9,34	5,19		
		64,1	66,1	79,6	112	200		75,7	78,9	83,3	143	280			96,8	98,6	111	215	400
125	134	10,4	6,69	3,72															
		59,1	61,6	65,6	112	200													
160	168	8,34	5,36	2,98															
		54,1	50,8	54,1	92,9	186													

4 - Selection tables

R 2EL .. + R CI ..

$L_h = 10\ 000\ h$

Summary of transmission ratios i_{eff} , nominal M_{N2} and peak M_{2max} torques

		Gear reducer size																			
		R 2EL 125A + R CI 180					R 2EL 180A + R CI 200					R 2EL 250A + R CI 225									
		n_1 min ⁻¹		M_{N2max} kN m		M_{2max} kN m		n_1 min ⁻¹		M_{N2max} kN m		M_{2max} kN m		n_1 min ⁻¹		M_{N2max} kN m		M_{2max} kN m			
		n_2 min ⁻¹	M_{N2} kN m	M_{N2max} kN m	M_{2max} kN m	n_2 min ⁻¹	M_{N2} kN m	M_{N2max} kN m	M_{2max} kN m	n_2 min ⁻¹	M_{N2} kN m	M_{N2max} kN m	M_{2max} kN m	n_2 min ⁻¹	M_{N2} kN m	M_{N2max} kN m	M_{2max} kN m	n_2 min ⁻¹	M_{N2} kN m	M_{N2max} kN m	M_{2max} kN m
i_N	i_{eff}	1400	900	500		i_{eff}	1400	900	500		i_{eff}	1400	900	500							
112						112	12.5	8.02	4.46												
							125	130	136	180	280										
125						125	11.2	7.19	3.99												
							120	123	127	180	280										
140						143	9.76	6.28	3.49						142	9.85	6.33	3.52			
							147	151	156	180	280					179	184	193	265	400	
150	145	9.65	6.20	3.45																	
		92.0	96.0	100	125	200															
160	163	8.60	5.53	3.07		160	8.75	5.63	3.13						163	8.60	5.53	3.07			
		104	108	112	125	200										204	211	221	265	400	
180	190	7.35	4.73	2.63		182	7.71	4.96	2.75						180	7.77	4.99	2.77			
		107	114	125	125	200										217	228	245	265	400	
200	212	6.60	4.24	2.36		196	7.14	4.59	2.55						207	6.78	4.36	2.42			
		109	116	124	125	200										219	232	254	265	400	
250	267	5.24	3.37	1.87		248	5.64	3.63	2.02						259	5.40	3.47	1.93			
		108	112	117	125	200										225	240	258	265	400	
280	300	4.67	3.00	1.67		285	4.91	3.15	1.75						283	4.94	3.18	1.76			
		113	120	125	125	200										227	236	245	265	400	
315	327	4.29	2.76	1.53		312	4.49	2.89	1.60						325	4.30	2.77	1.54			
		115	121	124	125	200										232	248	261	265	400	
355	382	3.67	2.36	1.31		340	4.11	2.64	1.47						354	3.95	2.54	1.41			
		117	118	118	125	200										237	253	263	265	400	
400	414	3.38	2.17	1.21		395	3.54	2.28	1.27						414	3.38	2.17	1.21			
		112	117	123	125	200										241	252	252	265	400	
450	449	3.12	2.00	1.11		433	3.24	2.08	1.16						449	3.12	2.00	1.11			
		94.0	100	109	112	200										243	254	264	265	400	
500	508	2.75	1.77	0.98		483	2.90	1.87	1.04						498	2.81	1.81	1.00			
		99.0	102	106	125	200										196	202	209	265	400	

4 - Selection tables

R 2EL .. + R CI ..

$L_h = 10\ 000\ h$

Summary of transmission ratios i_{eff} , nominal M_{N2} and peak M_{2max} torques

		Gear reducer size																
		R 2EL 355A + R CI 250					R 2EL 500A + R CI 280					R 2EL 710A + R CI 320						
		n_1 min ⁻¹		M_{N2max} M_{2max}			n_1 min ⁻¹		M_{N2max} M_{2max}			n_1 min ⁻¹		M_{N2max} M_{2max}				
		n_2 min ⁻¹	M_{N2} kN m	M_{2max} kN m	M_{2max} kN m		n_2 min ⁻¹	M_{N2} kN m	M_{2max} kN m	M_{2max} kN m		n_2 min ⁻¹	M_{N2} kN m	M_{2max} kN m	M_{2max} kN m			
i_N	i_{eff}	1400	900	500			i_{eff}	1400	900	500			i_{eff}	1400	900	500		
112	112	12.5	8.03	4.46									110	12.8	8.21	4.56		
		250	259	270	375	560								436	453	472	710	1120
125	124	11.3	7.25	4.03									128	10.9	7.02	3.90		
		256	263	272	375	560								510	530	552	710	1120
140	145	9.62	6.19	3.44			143	9.82	6.31	3.51			137	10.2	6.57	3.65		
		302	311	332	375	560		358	372	388	530	800		463	479	497	710	1120
150							157	8.89	5.72	3.18			153	9.15	5.88	3.27		
								395	411	428	530	800		517	536	556	710	1120
160	161	8.68	5.58	3.10			167	8.40	5.40	3.00			160	8.75	5.62	3.12		
		259	267	276	375	560		419	435	454	530	800		542	560	581	710	1120
180	182	7.70	4.95	2.75			184	7.61	4.89	2.72			179	7.83	5.03	2.79		
		307	323	337	375	560		432	456	498	530	800		584	616	650	710	1120
200	200	7.00	4.50	2.50			209	6.71	4.32	2.40			209	6.71	4.32	2.40		
		309	327	339	375	560		435	462	480	530	800		588	626	674	710	1120
250	252	5.55	3.57	1.98			264	5.31	3.41	1.90			262	5.35	3.44	1.91		
		317	332	344	375	560		419	435	454	530	800		566	586	610	710	1120
280	279	5.02	3.23	1.79			290	4.82	3.10	1.72			290	4.82	3.10	1.72		
		323	334	346	375	560		456	480	500	530	800		600	623	650	710	1120
315	312	4.48	2.88	1.60			323	4.33	2.79	1.55			333	4.20	2.70	1.50		
		327	336	349	375	560		465	485	498	530	800		563	585	606	710	1120
355	354	3.95	2.54	1.41			368	3.80	2.45	1.36			368	3.80	2.45	1.36		
		330	339	351	375	560		450	450	450	530	800		545	565	586	710	1120
400	396	3.53	2.27	1.26			409	3.42	2.20	1.22			403	3.48	2.23	1.24		
		332	342	354	375	560		444	462	482	530	800		573	585	596	710	1120
450	449	3.12	2.00	1.11			452	3.10	1.99	1.11			452	3.10	1.99	1.11		
		335	344	357	375	560		393	404	418	530	800		578	594	615	710	1120
500	498	2.81	1.81	1.00			502	2.79	1.79	1.00			494	2.83	1.82	1.01		
		278	286	297	375	560		395	406	421	530	800		582	598	619	710	1120

4 - Selection tables

R 2EL .. + R CI ..

$L_h = 25\ 000\ h$

Summary of transmission ratios i_{eff} nominal M_{N2} and peak M_{2max} torques

		Gear reducer size														
		R 2EL 125A + R CI 180					R 2EL 180A + R CI 200					R 2EL 250A + R CI 225				
		n_1 min ⁻¹		M_{N2max} M_{2max}		n_1 min ⁻¹		M_{N2max} M_{2max}		n_1 min ⁻¹		M_{N2max} M_{2max}				
		n_2 min ⁻¹	M_{N2} kN m	M_{2max} kN m	M_{2max} kN m	n_2 min ⁻¹	M_{N2} kN m	M_{2max} kN m	M_{2max} kN m	n_2 min ⁻¹	M_{N2} kN m	M_{2max} kN m	M_{2max} kN m			
i_N	i_{eff}	1400	900	500		i_{eff}	1400	900	500		i_{eff}	1400	900	500		
112						112	12.5	8.02	4.46							
							109	117	122	180	280					
125						125	11.2	7.19	3.99							
							113	116	120	180	280					
140						143	9.76	6.28	3.49			142	9.85	6.33	3.52	
							117	133	148	180	280		161	166	174	
150	145	9.65	6.20	3.45												
		83.0	87.0	90.0	125	200										
160	163	8.60	5.53	3.07		160	8.75	5.63	3.13			163	8.60	5.53	3.07	
		93.0	97.0	101	125	200		115	118	122	180	280		168	190	
180	190	7.35	4.73	2.63		182	7.71	4.96	2.75			180	7.77	4.99	2.77	
		101	104	107	125	200		125	143	150	180	280		174	198	
200	212	6.60	4.24	2.36		196	7.14	4.59	2.55			207	6.78	4.36	2.42	
		102	104	109	125	200		130	146	151	180	280		180	205	
250	267	5.24	3.37	1.87		248	5.64	3.63	2.02			259	5.40	3.47	1.93	
		97.0	101	105	125	200		139	148	153	180	280		192	215	
280	300	4.67	3.00	1.67		285	4.91	3.15	1.75			283	4.94	3.18	1.76	
		104	107	115	125	200		143	149	154	180	280		199	212	
315	327	4.29	2.76	1.53		312	4.49	2.89	1.60			325	4.30	2.77	1.54	
		105	107	112	125	200		146	150	155	180	280		205	218	
355	382	3.67	2.36	1.31		340	4.11	2.64	1.47			354	3.95	2.54	1.41	
		105	106	106	125	200		147	151	157	180	280		214	221	
400	414	3.38	2.17	1.21		395	3.54	2.28	1.27			414	3.38	2.17	1.21	
		101	105	110	125	200		148	152	158	180	280		216	225	
450	449	3.12	2.00	1.11		433	3.24	2.08	1.16			449	3.12	2.00	1.11	
		85.0	87.0	95.0	112	200		149	153	159	180	280		217	228	
500	508	2.75	1.77	0.98		483	2.90	1.87	1.04			498	2.81	1.81	1.00	
		94.0	96.0	100	125	200		123	126	131	180	280		186	191	

4 - Selection tables

R 2EL .. + R CI ..

$L_h = 25\ 000\ h$

Summary of transmission ratios i_{eff} , nominal M_{N2} and peak M_{2max} torques

		Gear reducer size																	
		R 2EL 355A + R CI 250					R 2EL 500A + R CI 280					R 2EL 710A + R CI 320							
		n_1 min ⁻¹						n_1 min ⁻¹						n_1 min ⁻¹					
		n_2 min ⁻¹	M_{N2max}	M_{2max}			n_2 min ⁻¹	M_{N2max}	M_{2max}			n_2 min ⁻¹	M_{N2max}	M_{2max}			n_2 min ⁻¹	M_{N2max}	M_{2max}
		M_{N2} kN m	kN m	kN m			M_{N2} kN m	kN m	kN m			M_{N2} kN m	kN m	kN m			M_{N2} kN m	kN m	kN m
i_N	i_{eff}	1400	900	500			i_{eff}	1400	900	500			i_{eff}	1400	900	500			
112	112	12.5	8.03	4.46									110	12.8	8.21	4.56			
		225	233	243	375	560								393	408	425	710	1120	
125	124	11.3	7.25	4.03									128	10.9	7.02	3.90			
		232	248	258	375	560								409	467	496	710	1120	
140	145	9.62	6.19	3.44			143	9.82	6.31	3.51			137	10.2	6.57	3.65			
		241	276	305	375	560		309	335	349	530	800		417	431	448	710	1120	
150							157	8.89	5.72	3.18			153	9.15	5.88	3.27			
								320	366	385	530	800		443	482	500	710	1120	
160	161	8.68	5.58	3.10			167	8.40	5.40	3.00			160	8.75	5.62	3.12			
		245	252	262	375	560		318	363	408	530	800		440	502	523	710	1120	
180	182	7.70	4.95	2.75			184	7.61	4.89	2.72			179	7.83	5.03	2.79			
		259	296	309	375	560		330	376	435	530	800		455	520	585	710	1120	
200	200	7.00	4.50	2.50			209	6.71	4.32	2.40			209	6.71	4.32	2.40			
		269	300	312	375	560		340	388	432	530	800		470	537	596	710	1120	
250	252	5.55	3.57	1.98			264	5.31	3.41	1.90			262	5.35	3.44	1.91			
		287	304	323	375	560		364	392	408	530	800		503	528	549	710	1120	
280	279	5.02	3.23	1.79			290	4.82	3.10	1.72			290	4.82	3.10	1.72			
		296	306	327	375	560		376	430	450	530	800		520	561	585	710	1120	
315	312	4.48	2.88	1.60			323	4.33	2.79	1.55			333	4.20	2.70	1.50			
		300	308	330	375	560		392	435	449	530	800		507	526	546	710	1120	
355	354	3.95	2.54	1.41			368	3.80	2.45	1.36			368	3.80	2.45	1.36			
		303	312	332	375	560		405	405	405	530	800		490	508	528	710	1120	
400	396	3.53	2.27	1.26			409	3.42	2.20	1.22			403	3.48	2.23	1.24			
		305	317	335	375	560		399	416	434	530	800		516	526	537	710	1120	
450	449	3.12	2.00	1.11			452	3.10	1.99	1.11			452	3.10	1.99	1.11			
		307	323	337	375	560		371	382	396	530	800		546	561	582	710	1120	
500	498	2.81	1.81	1.00			502	2.79	1.79	1.00			494	2.83	1.82	1.01			
		263	270	280	375	560		374	384	398	530	800		550	565	586	710	1120	

4 - Selection tables

R 2EL .. + R CI ..

$L_h = 50\ 000\ h$

Summary of transmission ratios i_{eff} nominal M_{N2} and peak M_{2max} torques

		Gear reducer size																	
		R 2EL 125A + R CI 180					R 2EL 180A + R CI 200					R 2EL 250A + R CI 225							
		n_1 min ⁻¹						n_1 min ⁻¹						n_1 min ⁻¹					
		n_2 min ⁻¹	M_{N2max}	M_{2max}			n_2 min ⁻¹	M_{N2max}	M_{2max}			n_2 min ⁻¹	M_{N2max}	M_{2max}			M_{N2} kN m	M_{N2max} kN m	M_{2max} kN m
i_N	i_{eff}	M_{N2} kN m	kN m	kN m			M_{N2} kN m	kN m	kN m			M_{N2} kN m	kN m	kN m			kN m	kN m	kN m
		1400	900	500			i_{eff}	1400	900	500			i_{eff}	1400	900	500			
112							112	12.5	8.02	4.46									
								88.0	99.0	103	180	280							
125							125	11.2	7.19	3.99									
								91.0	104	115	180	280							
140							143	9.76	6.28	3.49			142	9.85	6.33	3.52			
								95.0	108	129	180	280		131	141	147	265	400	
150	145	9.65	6.20	3.45															
		70.0	73.0	76.0	125	200													
160	163	8.60	5.53	3.07			160	8.75	5.63	3.13			163	8.60	5.53	3.07			
		79.0	82.0	86.0	125	200		98.0	112	117	180	280		136	155	169	265	400	
180	190	7.35	4.73	2.63			182	7.71	4.96	2.75			180	7.77	4.99	2.77			
		88.0	96.0	100	125	200		102	116	139	180	280		141	161	187	265	400	
200	212	6.60	4.24	2.36			196	7.14	4.59	2.55			207	6.78	4.36	2.42			
		88.0	91.0	94.0	125	200		106	120	144	180	280		146	167	199	265	400	
250	267	5.24	3.37	1.87			248	5.64	3.63	2.02			259	5.40	3.47	1.93			
		82.0	86.0	89.0	125	200		113	129	144	180	280		156	178	213	265	400	
280	300	4.67	3.00	1.67			285	4.91	3.15	1.75			283	4.94	3.18	1.76			
		93.0	96.0	100	125	200		116	133	148	180	280		161	180	187	265	400	
315	327	4.29	2.76	1.53			312	4.49	2.89	1.60			325	4.30	2.77	1.54			
		90.0	93.0	95.0	125	200		120	138	149	180	280		167	190	214	265	400	
355	382	3.67	2.36	1.31			340	4.11	2.64	1.47			354	3.95	2.54	1.41			
		90.0	90.0	90.0	125	200		125	143	148	180	280		174	198	206	265	400	
400	414	3.38	2.17	1.21			395	3.54	2.28	1.27			414	3.38	2.17	1.21			
		85.0	89.0	93.0	125	200		130	146	151	180	280		179	192	192	265	400	
450	449	3.12	2.00	1.11			433	3.24	2.08	1.16			449	3.12	2.00	1.11			
		82.0	84.0	87.0	112	200		134	147	148	180	280		185	193	202	265	400	
500	508	2.75	1.77	0.98			483	2.90	1.87	1.04			498	2.81	1.81	1.00			
		90.0	92.0	96.0	125	200		118	121	126	180	280		178	183	189	265	400	

4 - Selection tables

R 2EL .. + R CI ..

$L_h = 50\ 000\ h$

Summary of transmission ratios i_{eff} , nominal M_{N2} and peak M_{2max} torques

		Gear reducer size																			
		R 2EL 355A + R CI 250					R 2EL 500A + R CI 280					R 2EL 710A + R CI 320									
		n_1 min ⁻¹		M_{N2max} kN m		M_{2max} kN m		n_1 min ⁻¹		M_{N2max} kN m		M_{2max} kN m		n_1 min ⁻¹		M_{N2max} kN m		M_{2max} kN m			
		n_2 min ⁻¹	M_{N2} kN m	M_{N2max} kN m	M_{2max} kN m	n_2 min ⁻¹	M_{N2} kN m	M_{N2max} kN m	M_{2max} kN m	n_2 min ⁻¹	M_{N2} kN m	M_{N2max} kN m	M_{2max} kN m	n_2 min ⁻¹	M_{N2} kN m	M_{N2max} kN m	M_{2max} kN m	n_2 min ⁻¹	M_{N2} kN m	M_{N2max} kN m	M_{2max} kN m
i_N	i_{eff}	1400	900	500		i_{eff}	1400	900	500		i_{eff}	1400	900	500							
112	112	12.5	8.03	4.46							110	12.8	8.21	4.56							
		183	198	206	375	560						323	346	360	710	1120					
125	124	11.3	7.25	4.03							128	10.9	7.02	3.90							
		189	215	228	375	560						332	379	421	710	1120					
140	145	9.62	6.19	3.44						143	9.82	6.31	3.51								
		196	224	267	375	560					251	284	296	530	800						
150										157	8.89	5.72	3.18								
											260	297	326	530	800						
160	161	8.68	5.58	3.10						167	8.40	5.40	3.00								
		202	231	250	375	560					258	332	346	530	800						
180	182	7.70	4.95	2.75						184	7.61	4.89	2.72								
		211	240	285	375	560					268	306	365	530	800						
200	200	7.00	4.50	2.50						209	6.71	4.32	2.40								
		218	249	297	375	560					276	316	366	530	800						
250	252	5.55	3.57	1.98						264	5.31	3.41	1.90								
		233	266	295	375	560					295	332	346	530	800						
280	279	5.02	3.23	1.79						290	4.82	3.10	1.72								
		241	275	304	375	560					306	349	381	530	800						
315	312	4.48	2.88	1.60						323	4.33	2.79	1.55								
		249	284	306	375	560					318	363	380	530	800						
355	354	3.95	2.54	1.41						368	3.80	2.45	1.36								
		259	292	299	375	560					330	343	343	530	800						
400	396	3.53	2.27	1.26						409	3.42	2.20	1.22								
		269	300	312	375	560					338	352	367	530	800						
450	449	3.12	2.00	1.11						452	3.10	1.99	1.11								
		277	296	299	375	560					343	366	379	530	800						
500	498	2.81	1.81	1.00						502	2.79	1.79	1.00								
		252	259	269	375	560					354	368	382	530	800						

5 - Main dimensions

Cylindrical shaft

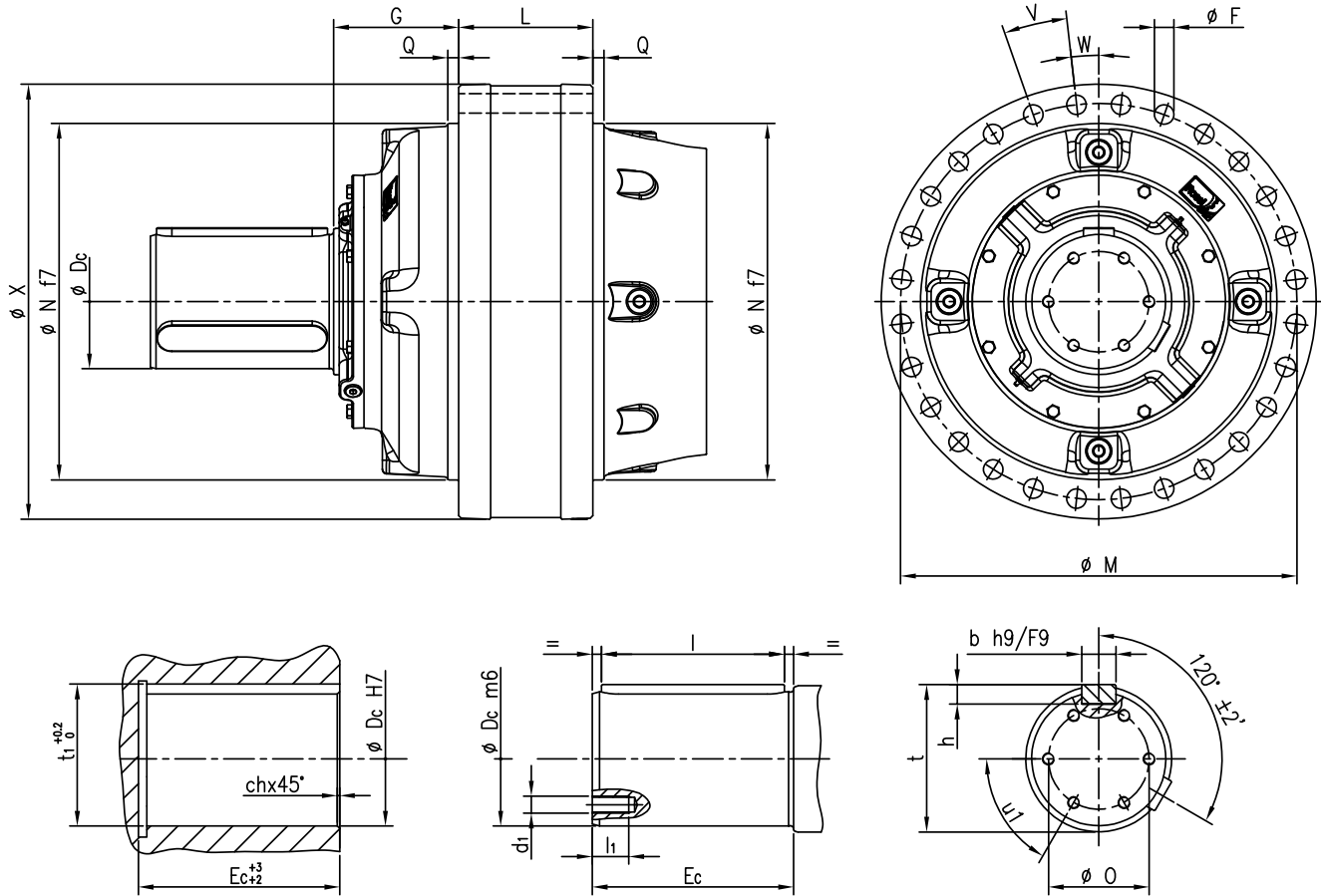

Size	Ordering code	X	N	G	L	Q	M	F	V	W	D _c	E _c	d ₁	l ₁	O	u ₁	b x h x l	t	t ₁	ch
042A	C120M1 F10f	410	340	130	135	12.5	370	16.5	28x12,857°	6,429°	120	165	M16	35	85	3x120°	32 x 18 x 150	127	127.4	3
060A	C140M1 F10g	445	365	135	150	12.5	400	21	24x15°	7,5°	140	200	M16	33	100	3x120°	36 x 20 x 180	148	148.4	2.5
085A	C160M1 F10h	506	425	150	160	12.5	460	21	28x12,857°	6,429°	160	240	M16	33	115	3x120°	40 x 22 x 220	169	169.4	2
125A	C180M1 F10i	570	470	170	175	12,5	515	25	28x12,857°	6,429°	180	240	M16	35	130	3x120°	45 x 25 x 220	190	190.4	2
180A	C200M1 F10j	630	520	195	195	16,5	575	25	32x11,25°	5,625°	200	280	M20	40	150	3x120°	45 x 25 x 250	210	210.4	4
250A	C220M1 F10k	715	585	205	220	18	650	32	28x12,857°	6,428°	220	300	M20	40	165	6x60°	50 x 28 x 280	231	231.4	5
355A	C250M1 F10l	805	665	230	255	15	735	32	32x11,25°	5,625°	250	330	M24	48	200	6x60°	56 x 32 x 300	262	262.4	5
500A	C280M1 F10m	885	730	265	275	18	810	38	28x12,857°	6,429°	280	380	M27	54	210	6x60°	63 x 32 x 360	292	292.4	6
710A	C320M1 F10n	970	810	290	300	20	890	38	32x11,25°	5,625°	320	430	M30	60	240	6x60°	70 x 36 x 400	334	334.4	5

5 - Main dimensions

Splined shaft

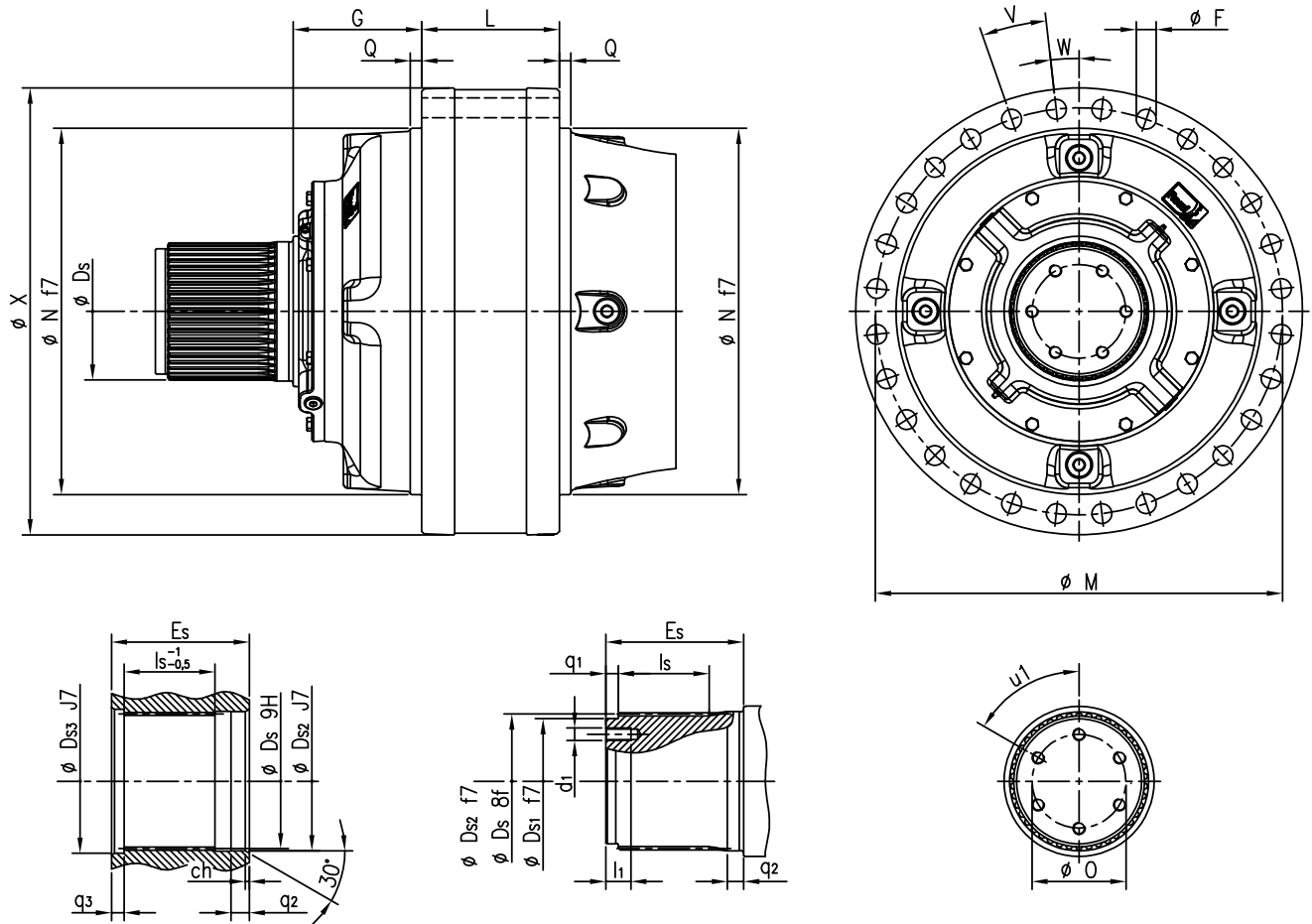

Size	Ordering code	X	N	G	L	Q	M	F	V	W	D_s DIN 5480	E_s	D_{s1}	D_{s2}	d_1	l_1	O	u_1	l_s	q_1	q_2	ch	D_{s3}	q_3
042A	S120M1 F10f	410	340	130	135	12.5	370	16.5	28x12,857°	6,429°	W120x3	130	100	122	M16	35	70	3x120°	86	10	13,5	3	122	10
060A	S130M1 F10g	445	365	135	150	12.5	400	21	24x15°	75°	W130x3	130	110	132	M16	33	80	3x120°	88	10	13,5	3,5	132	10
085A	S150M1 F10h	506	425	150	160	12.5	460	21	28x12,857°	6,429°	W150x5	150	125	151	M16	33	95	3x120°	107	12	14	3	151	12
125A	S170M1 F10i	570	470	170	175	12,5	515	25	28x12,857°	6,429°	W170x5	170	150	172	M16	35	115	4x90°	115	17	22	5,5	175	17
180A	S200M1 F10j	630	520	195	195	16,5	575	25	32x11,25°	5,625°	W200x5	200	180	202	M20	40	135	4x90°	135	18	24	6	210	18
250A	S220M1 F10k	715	585	205	220	18	650	32	28x12,857°	6,429°	W220x5	220	200	222	M20	40	150	6x60°	145	20	29	6,5	230	20
355A	S240M1 F10l	805	665	230	255	15	735	32	32x11,25°	5,625°	W240x5	240	220	242	M24	48	165	6x60°	165	22	28	7	260	22
500A	S280M1 F10m	885	730	265	275	18	810	38	28x12,857°	6,429°	W280x8	280	250	285	M27	54	190	6x60°	190	24	32	10,5	290	24
710A	S300M1 F10n	970	810	290	300	20	890	38	32x11,25°	5,625°	W300x8	300	270	305	M30	60	200	6x60°	200	26	34	10,5	320	26

5 - Main dimensions

Hollow shaft

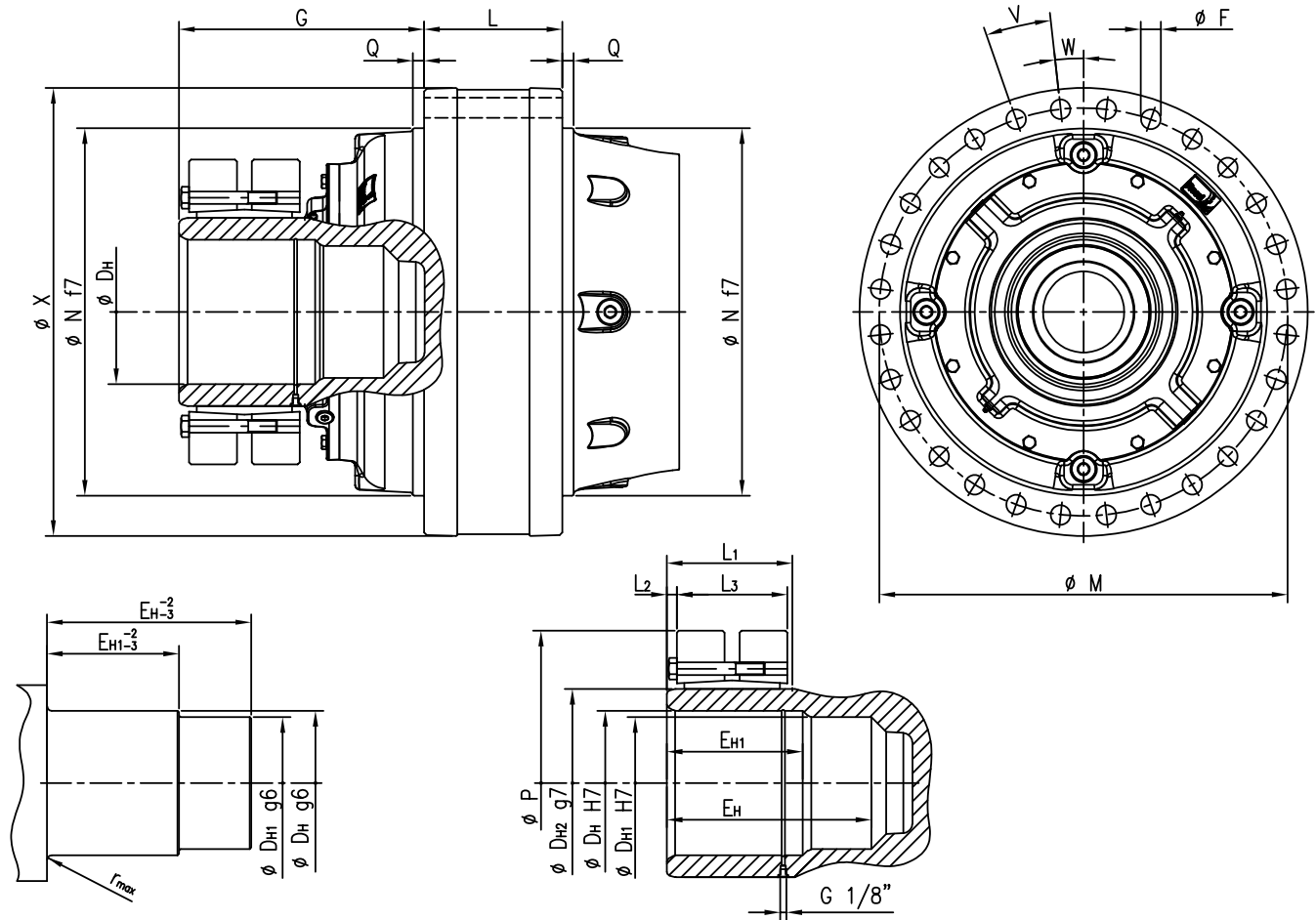

Size	Ordering code	X	N	G	L	Q	M	F	V	W	D _H	E _H	D _{H1}	E _{H1}	D _{H2}	L ₁	P	L ₂	L ₃	r _{max}
042A	H130M1 A10f	410	340	205	135	12.5	370	16.5	28x12,857°	6,429°	130	168	120	110	165	98	290	88	98	3
060A	H140M1 A10g	445	365	235	150	12.5	400	21	24x15°	7,5°	140	195	130	130	185	122	330	112	122	3
085A	H160M1 A10h	506	425	252	160	12.5	460	21	28x12,857°	6,429°	160	212	150	130	200	122	350	112	122	3.5
125A	H180M1 A10i	570	470	300	175	12,5	515	25	28x12,857°	6,429°	180	260	165	170	240	157,5	405	13,5	144	4
180A	H200M1 A10j	630	520	350	195	16,5	575	25	32x11,25°	5,625°	200	285	185	185	260	180	430	13	160	5
250A	H230M1 A10k	715	585	390	220	18	650	32	28x12,857°	6,429°	230	325	210	210	300	200	485	16	176	6
355A	H260M1 A10l	805	665	420	255	15	735	32	32x11,25°	5,625°	260	365	240	230	340	225	570	15	200	6
500A	H280M1 A10m	885	730	470	275	18	810	38	28x12,857°	6,429°	280	405	260	250	360	227	590	15	204	7
710A	H340M1 A10n	970	810	510	300	20	890	38	32x11,25°	5,625°	340	440	315	280	420	275	690	15	238	8

5 - Main dimensions

Splined hollow shaft

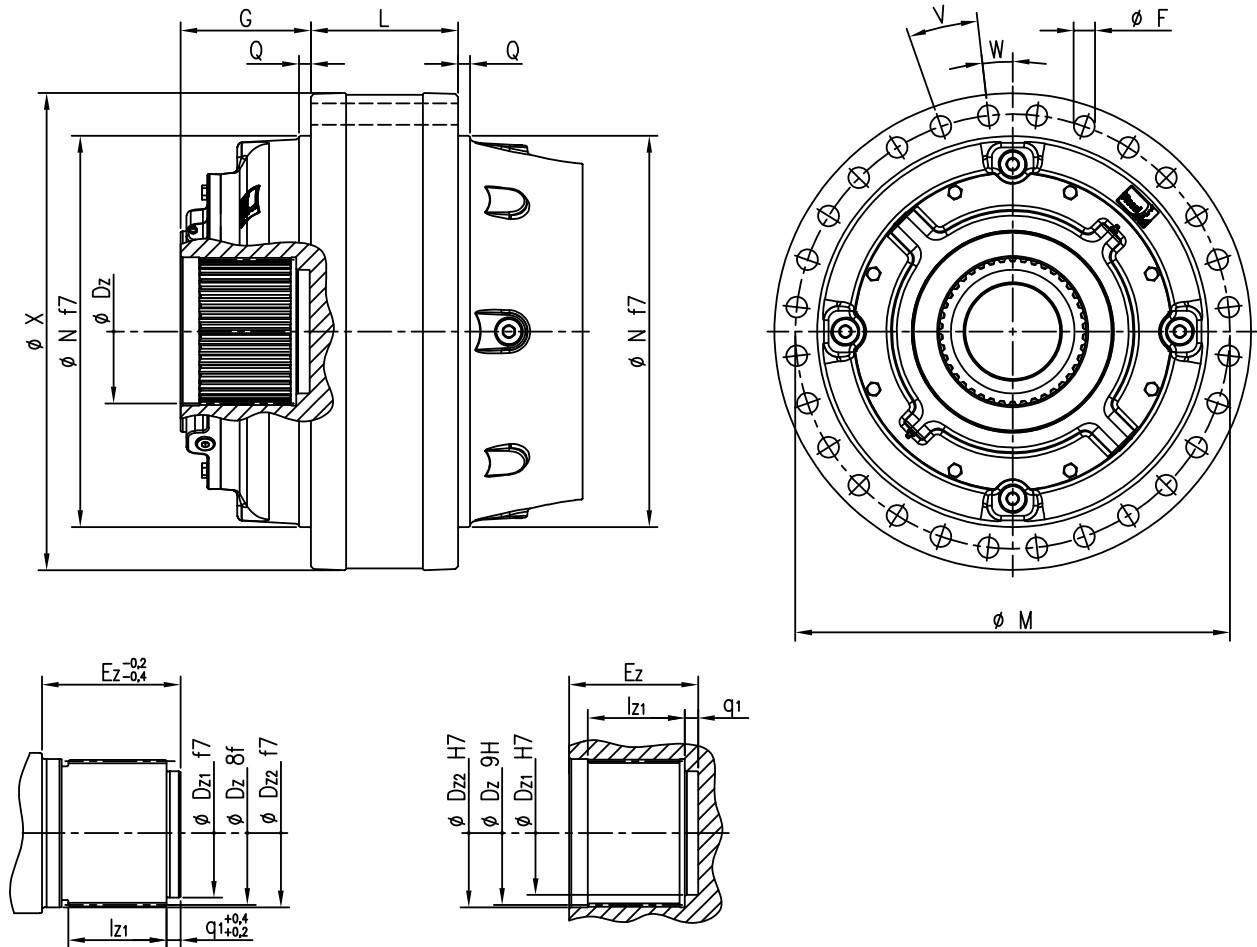

Size	Ordering code	X	N	G	L	Q	M	F	V	W	D _Z DIN 5480	E _Z	D _{Z1}	D _{Z2}	l _{Z1}	q ₁
042A	Z120M1 F05f	410	340	105	135	12.5	370	16.5	28x12,857°	6,429°	N120x3	110	102	122	80	13
060A	Z130M1 F05g	445	365	110	150	12.5	400	21	24x15°	7,5°	N130x3	118	112	132	85	14
085A	Z150M1 F05h	506	425	130	160	12.5	460	21	28x12,857°	6,429°	N150x5	135	128	152	100	15
125A	Z170M1 F05i	570	470	145	175	12,5	515	25	28x12,857°	6,429°	N170x5	148	145	172	110	16
180A	Z200M1 F05j	630	520	175	195	16,5	575	25	32x11,25°	5,625°	N200x5	173	170	202	130	18
250A	Z220M1 F05k	715	585	195	220	18	650	32	28x12,857°	6,429°	N220x5	193	185	222	145	20
355A	Z240M1 F05l	805	665	200	255	15	735	32	32x11,25°	5,625°	N240x5	212	205	242	160	22
500A	Z280M1 F05m	885	730	225	275	18	810	38	28x12,857°	6,429°	N280x8	236	235	282	180	24
710A	Z300M1 F05n	970	810	245	300	20	890	38	32x11,25°	5,625°	N300x8	261	250	302	200	26

5 - Main dimensions R 1EL .. + R CI ..

Overall dimensions

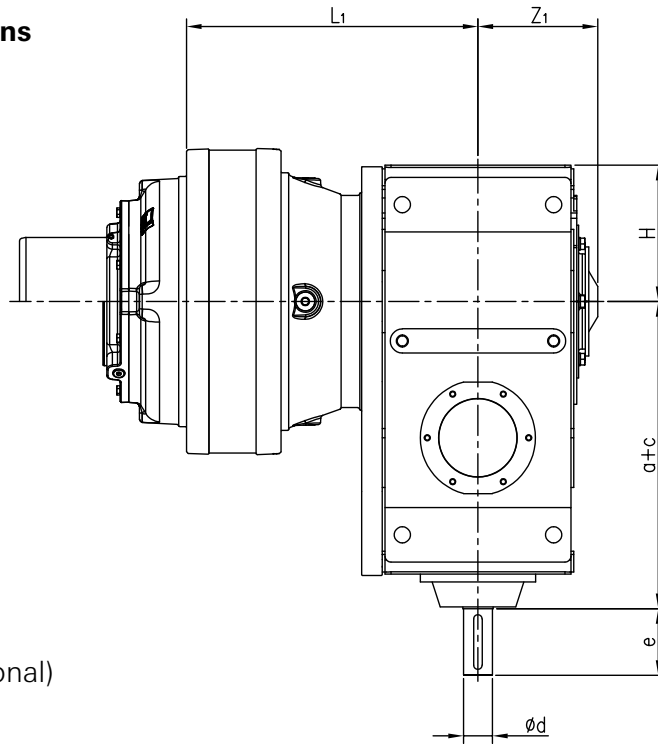

Fan cooling (optional)

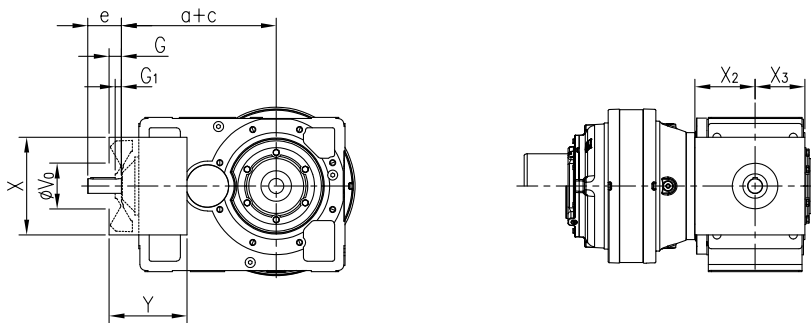

Size	L_1	Z_1	H	a+c	d	e	G	G_1	V_0	Y	a+c	d	e	G	G_1	V_0	Y	a+c	d	e	G	G_1	V_0	Y	X	X_2	X_3
R 1EL 042A + R CI 180	394.5	170	180	426	48 k6	110	34	20	110	209	406	38 k6	80	29	15	110	184	406	32 k6	80	-	-	-	-	264	162	132
R 1EL 060A + R CI 200	456.5	185	225	505	55 m6	110	41	20	150	255	482	48 k6	110	41	20	130	232	482	38 k6	80	-	-	-	-	326	194	163
R 1EL 085A + R CI 225	485	203	225	530	55 m6	110	41	20	150	255	507	48 k6	110	41	20	130	232	507	38 k6	80	-	-	-	-	326	194	163
R 1EL 125A + R CI 250	543	228	280	630	70 m6	140	47	25	175	317	607	55 m6	110	46	25	150	293	607	48 k6	110	46	20	150	293	426	230	202
R 1EL 180A + R CI 280	621	243	280	660	70 m6	140	47	25	175	317	637	55 m6	110	46	25	150	293	637	48 k6	110	46	20	150	293	426	240	202
R 1EL 250A + R CI 320	709	292	355	800	90 m6	170	57	32	220	392								800	70 m6	140	57	32	220	392	554	295	250

5 - Main dimensions R 2EL .. + R CI ..

Overall dimensions

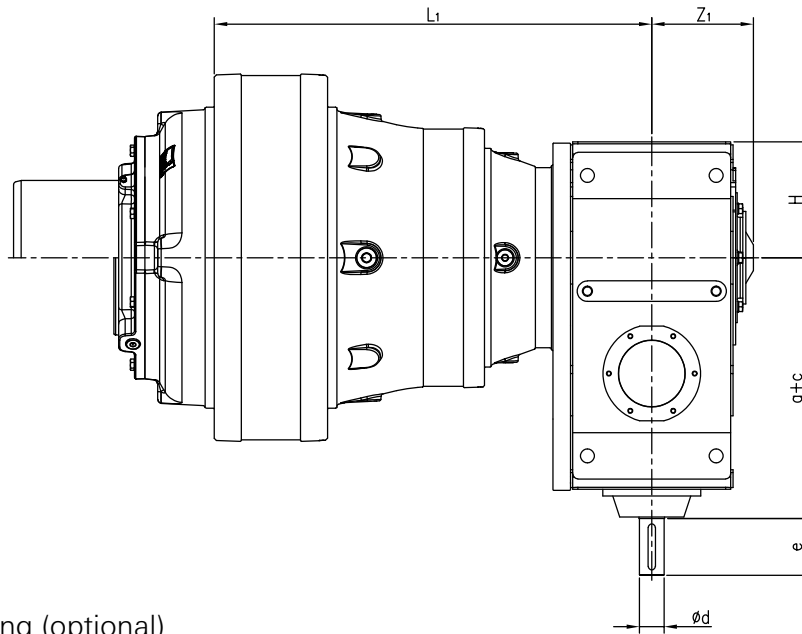

Fan cooling (optional)

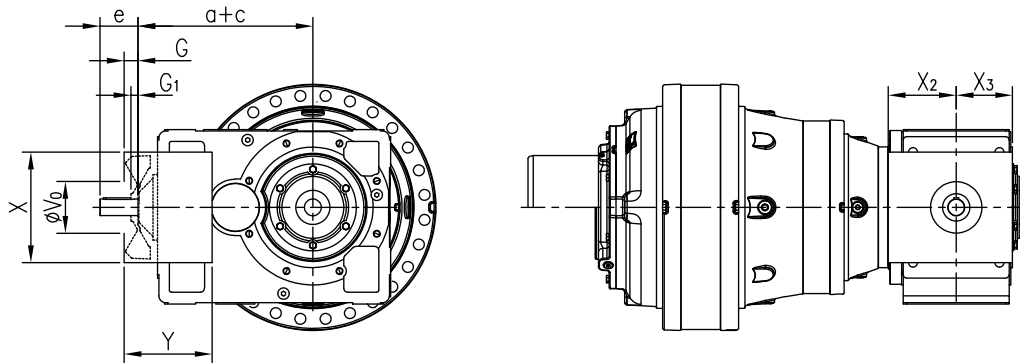

Size	L_1	Z_1	H	$a+c$	d	e	G	G_1	V_0	Y	$a+c$	d	e	G	G_1	V_0	Y	$a+c$	d	e	G	G_1	V_0	Y	X	X_2	X_3
R 2EL 125A + R CI 180	655	170	180	426	48 k6	110	34	20	110	209	406	38 k6	80	29	15	110	184	406	32 k6	80	-	-	-	-	264	162	132
R 2EL 180A + R CI 200	775	185	225	505	55 m6	110	41	20	150	255	482	48 k6	110	41	20	130	232	482	38 k6	80	-	-	-	-	326	194	163
R 2EL 250A + R CI 225	850	203	225	530	55 m6	110	41	20	150	255	507	48 k6	110	41	20	130	232	507	38 k6	80	-	-	-	-	326	194	163
R 2EL 355A + R CI 250	956	228	280	630	70 m6	140	47	25	175	317	607	55 m6	110	46	25	150	293	607	48 k6	110	46	20	150	293	426	230	202
R 2EL 500A + R CI 280	1090	243	280	660	70 m6	140	47	25	175	317	637	55 m6	110	46	25	150	293	637	48 k6	110	46	20	150	293	426	240	202
R 2EL 710A + R CI 320	1215	292	355	800	90 m6	170	57	32	220	392								800	70 m6	140	57	32	220	392	554	295	250

6 - Mounting positions

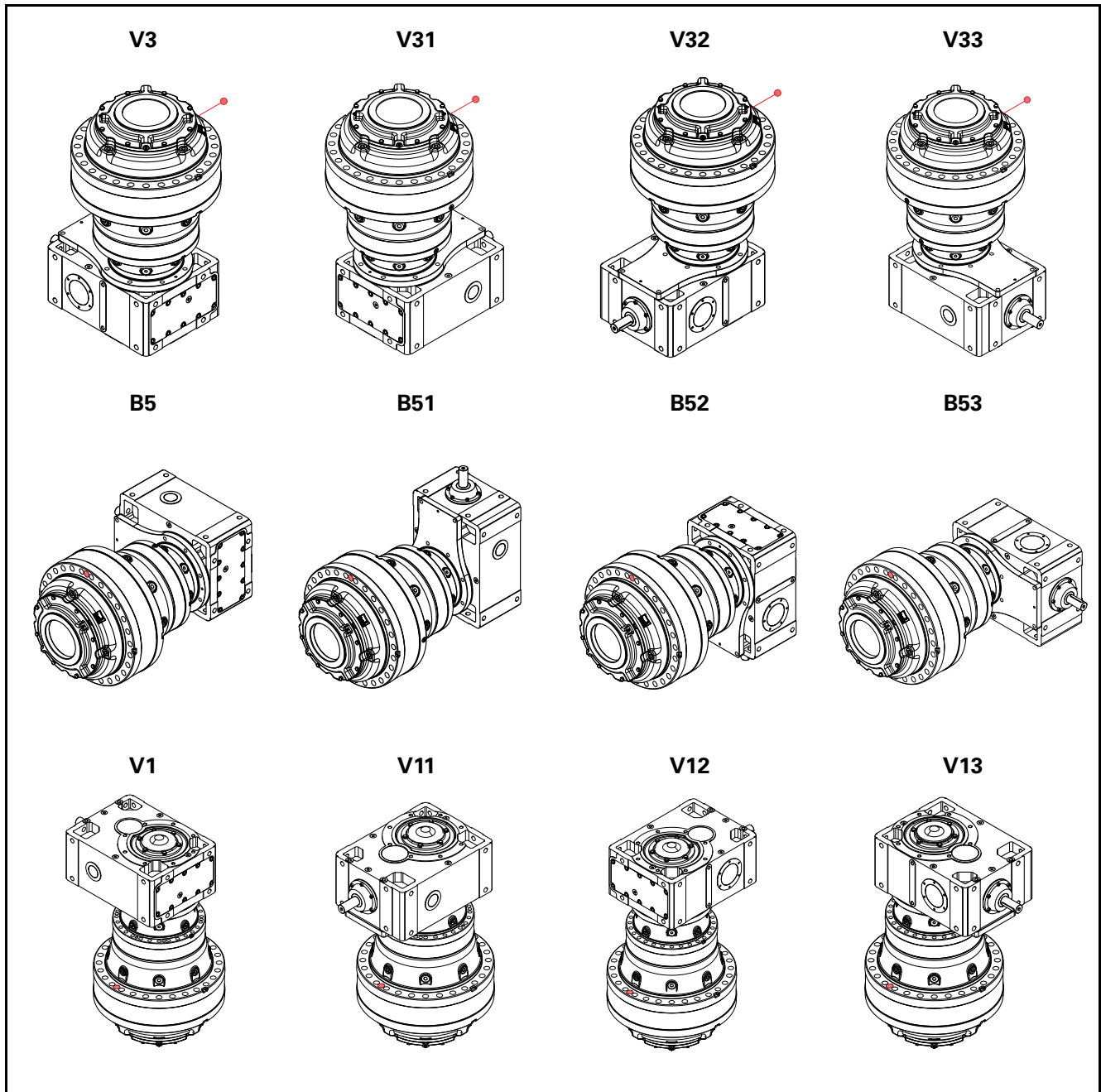

• Reference hole for the identification of the mounting position

Oil quantities and masses

Size	Oil quantity [l]						Mass [kg]			
	B5	B51	B52	B53	V3 ... V33	V1 ... V13	C...	S...	H...	Z...
R 1EL 042A	4	4	4	4	8	8	426	423	415	419
R CI 180	9	16,5	14,8	12,8	16,5	16,5				
R 1EL 060A	5,5	5,5	5,5	5,5	11	11	650	641	640	641
R CI 200	15	22,4	20	15	22,4	22,4				
R 1EL 085A	6,2	6,2	6,2	6,2	12,4	12,4	815	800	805	805
R CI 225	17	31,5	28	24	31,5	31,5				
R 1EL 125A	11	11	11	11	22	22	1210	1190	1155	1130
R CI 250	28	42,5	37,5	28	42,5	42,5				
R 1EL 180A	18	18	18	18	36	36	1530	1505	1440	1400
R CI 280	32	60	53	45	60	60				
R 1EL 250A	25	25	25	25	50	50	2050	2020	1970	1920
R CI 320	53	80	71	53	80	80				
R 2EL 125A	13	13	13	13	26	26	770	750	730	710
R CI 180	9	16,5	14,8	12,8	16,5	16,5				
R 2EL 180A	21	21	21	21	42	42	1110	1090	1050	1010
R CI 200	15	22,4	20	15	22,4	22,4				
R 2EL 250A	30	30	30	30	60	60	1480	1460	1440	1390
R CI 225	17	31,5	28	24	31,5	31,5				
R 2EL 355A	43	43	43	43	86	86	2190	2160	2090	2030
R CI 250	28	42,5	37,5	28	42,5	42,5				
R 2EL 500A	56	56	56	56	112	112	2980	2930	2830	2740
R CI 280	32	60	53	45	60	60				
R 2EL 710A	81	81	81	81	162	162	4070	3980	3820	3730
R CI 320	53	80	71	53	80	80				

Thermal Power P_t [kW] effects

Generally, in usual operating conditions, the nominal thermal power P_{t_N} of combined gear reducer is determined by right angle shaft gear reducer on high speed shaft.

However, in specific operating conditions (high speed, continuous and/or very frequent duty, difficult mounting positions as V1, V3 or similar ones), it is possible that the usual operation generates a progressive overheating of the planetary gear reducer EP, affecting the thermal power value admitted by the combined gear reducer.

Verify that applied power P_1 is lower than or equal to the nominal thermal power P_{t_N} , and consult/(apply the selection criteria stated at chapter "Thermal power P_t " of G series and EP series catalogs. The nominal thermal power P_{t_N} of combined gear reducer will be the minimum value calculated.

However it is always possible to increase the thermal power of combined unit through an integrated cooling system or an independent cooling unit. Contact us for further information.

Input and output radial (F_r) and axial (F_a) loads

Verify that radial (F_r) and axial loads (F_a) applied on the input and output shafts are lower than the performances of selected size, and consult/apply the selection criteria stated at the relevant chapters of G series and EP series catalogs.

7 - Accessories



Stop washer

Size	Ordering code
042A	,SW120
060A	,SW130
085A	,SW150
125A	,SW170
180A	,SW200
250A	,SW220
355A	,SW240
500A	,SW280
710A	,SW300



Splined bush

Size	Ordering code
042A	,SB120
060A	,SB130
085A	,SB150
125A	,SB170
180A	,SB200
250A	,SB220
355A	,SB240
500A	,SB280
710A	,SB300

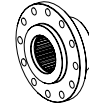

Wheel flange

Size	Ordering code
042A	,WF120
060A	,WF130
085A	,WF150
125A	,WF170
180A	,WF200
250A	,WF220
355A	,WF240
500A	,WF280
710A	,WF300





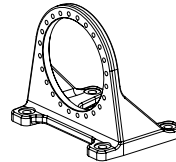

Splined bar

Size	Ordering code
042A	,SC120
060A	,SC130
085A	,SC150
125A	,SC170
180A	,SC200
250A	,SC220
355A	,SC240
500A	,SC280
710A	,SC300



Foot bracket

Size	Stand alone	Ordering code			
					
042A	,FB10f	,FB13f	,FB16f	,FB17f	,FB18f
060A	,FB10g	,FB13g	,FB16g	,FB17g	,FB18g
085A	,FB10h	,FB13h	,FB16h	,FB17h	,FB18h
125A	,FB10i	,FB13i	,FB16i	,FB17i	,FB18i
180A	,FB10j	,FB13j	,FB16j	,FB17j	,FB18j
250A	,FB10k	,FB13k	,FB16k	,FB17k	,FB18k
355A	,FB10l	,FB13l	,FB16l	,FB17l	,FB18l
500A	,FB10m	,FB13m	,FB16m	,FB17m	,FB18m
710A	,FB10n	,FB13n	,FB16n	,FB17n	,FB18n



Shrink disc

Size	Ordering code
042A	,SD165
060A	,SD185
085A	,SD200
125A	,SD240
180A	,SD260
250A	,SD300
355A	,SD340
500A	,SD360
710A	,SD420



Rossi

Solutions for
an evolving
industry

Rossi S.p.A.

Via Emilia Ovest 915/A
41123 Modena - Italy

Phone +39 059 33 02 88

info@rossi.com
www.rossi.com

Edition April 2018

© Rossi S.p.A. Rossi reserves the right to make any modification whenever to this publication contents. The information given in this document only contains general descriptions and/or performance features which may not always specifically reflect those described.

The Customer is responsible for the correct selection and application of product in view of its industrial and/or commercial needs, unless the use has been recommended by technical qualified personnel of Rossi, who were duly informed about Customer's application purposes. In this case all the necessary data required for the selection shall be communicated exactly and in writing by the Customer, stated in the order and confirmed by Rossi. The Customer is always responsible for the safety of product applications. Every care has been taken in the drawing up of the catalog to ensure the accuracy of the information contained in this publication, however Rossi can accept no responsibility for any errors, omissions or outdated data. Due to the constant evolution of the state of the art, Rossi reserves the right to make any modification whenever to this publication contents. The responsibility for the product selection is of the Customer, excluding different agreements duly legalized in writing and undersigned by the Parties.